

<p><b>PROPRIETARY AND CONFIDENTIAL</b></p> <p>THE INFORMATION CONTAINED IN THIS DRAWING IS THE SOLE PROPERTY OF &lt;INSERT COMPANY NAME HERE&gt;. ANY REPRODUCTION IN PART OR AS A WHOLE WITHOUT THE WRITTEN PERMISSION OF &lt;INSERT COMPANY NAME HERE&gt; IS PROHIBITED.</p>			UNLESS OTHERWISE SPECIFIED:		NAME	DATE	UBC Okanagan TITLE:		
			DIMENSIONS ARE IN INCHES TOLERANCES: FRACTIONAL ± ANGULAR: MACH ± BEND ± TWO PLACE DECIMAL ± THREE PLACE DECIMAL ±	DRAWN			Sprocket & Chain		
			INTERPRET GEOMETRIC TOLERANCING PER:	CHECKED			SIZE	DWG. NO.	REV
			MATERIAL	ENG APPR.			Sprocket & Chain Anime		
	NEXT ASSY	USED ON	FINISH	MFG APPR.			SCALE: 1:2	WEIGHT:	SHEET 1 OF 1
	APPLICATION		DO NOT SCALE DRAWING	Q.A.					
				COMMENTS:					

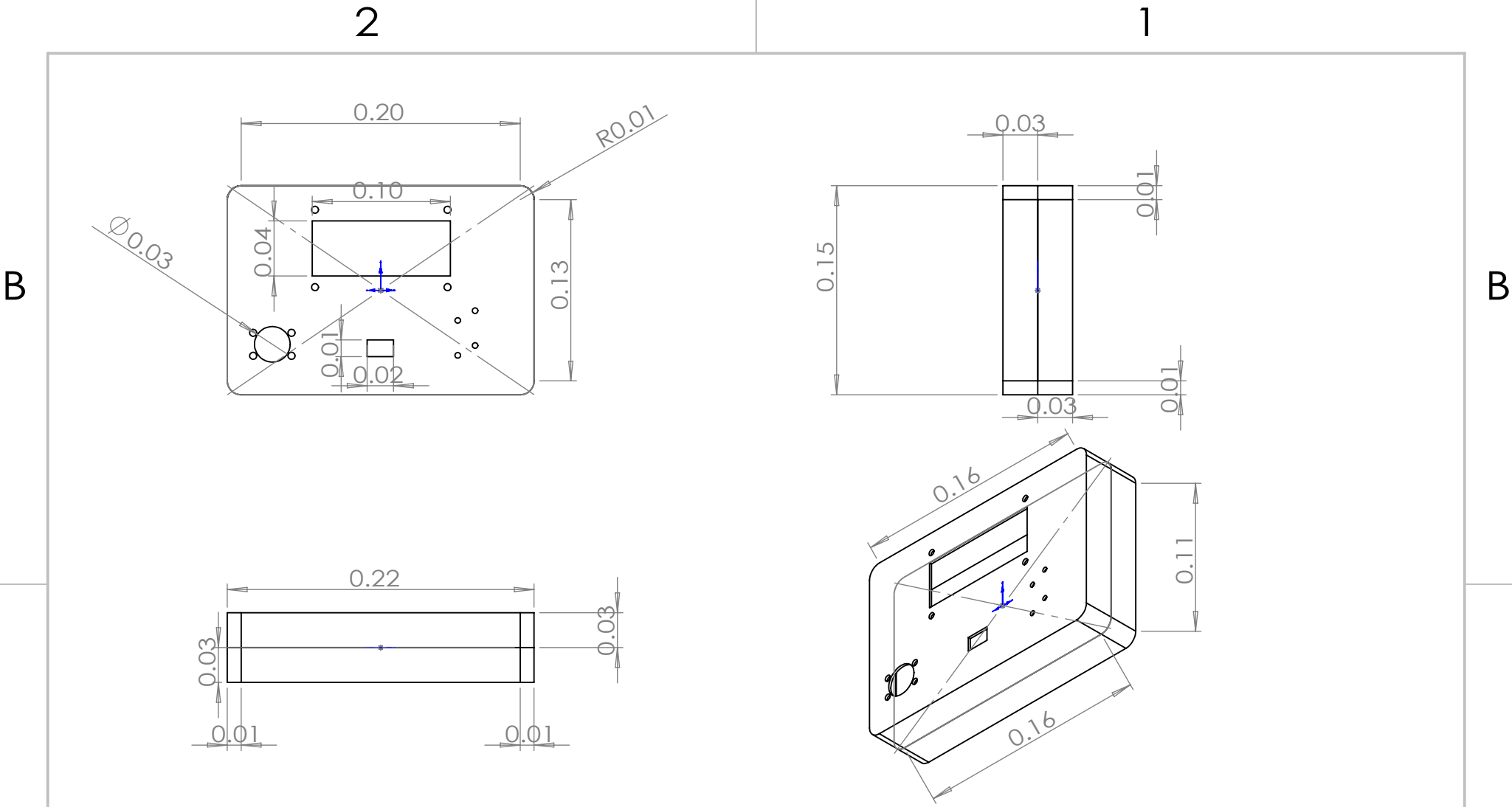



B

B

A

A

**PROPRIETARY AND CONFIDENTIAL**  
 THE INFORMATION CONTAINED IN THIS DRAWING IS THE SOLE PROPERTY OF <INSERT COMPANY NAME HERE>. ANY REPRODUCTION IN PART OR AS A WHOLE WITHOUT THE WRITTEN PERMISSION OF <INSERT COMPANY NAME HERE> IS PROHIBITED.

		UNLESS OTHERWISE SPECIFIED:		NAME	DATE
		DIMENSIONS ARE IN INCHES	DRAWN		
		TOLERANCES:	CHECKED		
		FRACTIONAL $\pm$	ENG APPR.		
		ANGULAR: MACH $\pm$ BEND $\pm$	MFG APPR.		
		TWO PLACE DECIMAL $\pm$	Q.A.		
		THREE PLACE DECIMAL $\pm$	COMMENTS:		
		INTERPRET GEOMETRIC TOLERANCING PER:			
		MATERIAL			
		FINISH			
NEXT ASSY	USED ON				
APPLICATION		DO NOT SCALE DRAWING			

UBC Okanagan		
TITLE:		
Controller		
SIZE	DWG. NO.	REV
<b>A</b>	Assem2(1)	
SCALE: 1:2	WEIGHT:	SHEET 1 OF 1

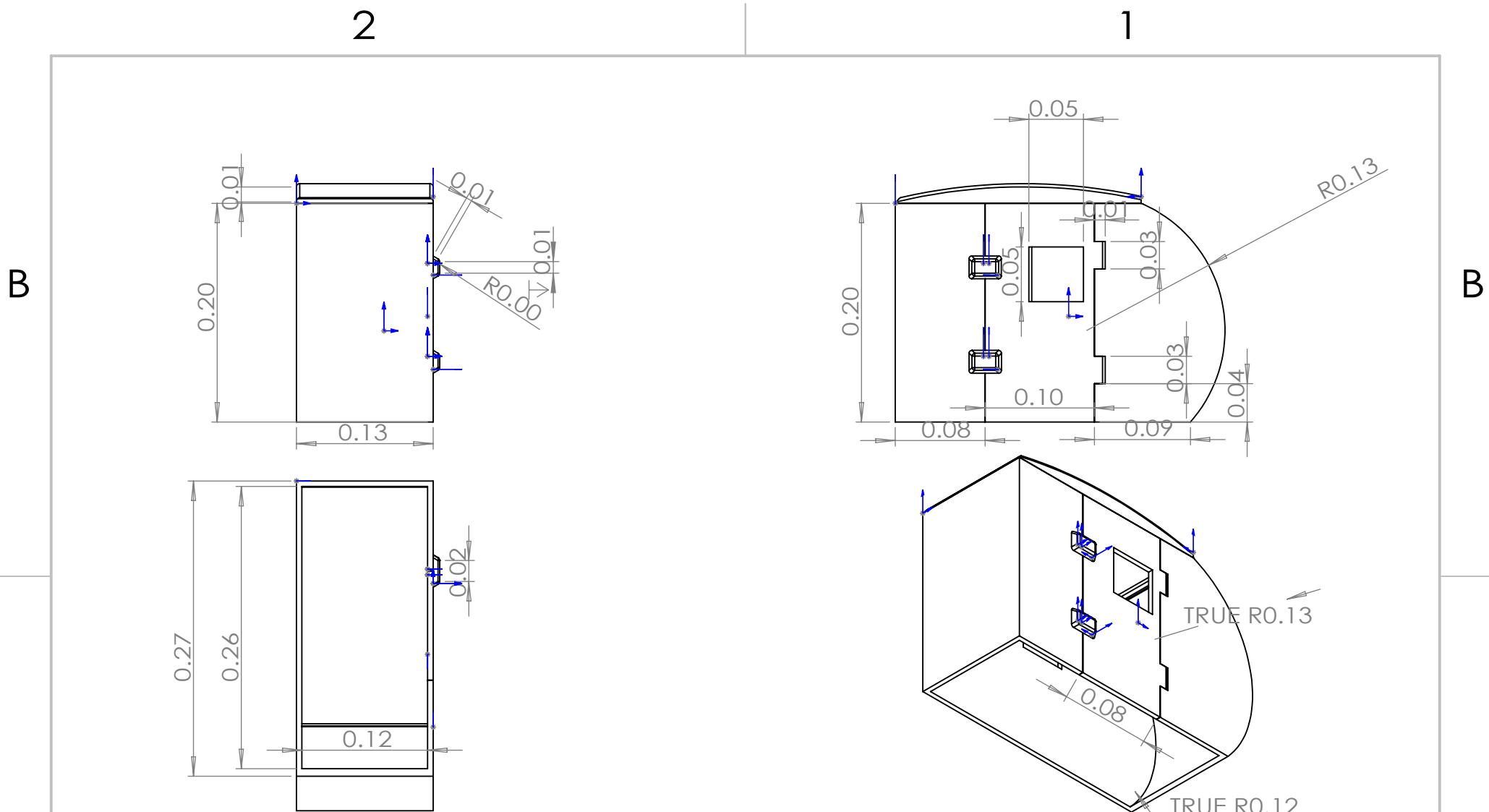

<p><b>PROPRIETARY AND CONFIDENTIAL</b></p> <p>THE INFORMATION CONTAINED IN THIS DRAWING IS THE SOLE PROPERTY OF &lt;INSERT COMPANY NAME HERE&gt;. ANY REPRODUCTION IN PART OR AS A WHOLE WITHOUT THE WRITTEN PERMISSION OF &lt;INSERT COMPANY NAME HERE&gt; IS PROHIBITED.</p>			UNLESS OTHERWISE SPECIFIED:		NAME	DATE	<p>UBC Okanagan</p> <p>TITLE:</p> <p>Outer Shell</p>	
			DIMENSIONS ARE IN INCHES TOLERANCES: FRACTIONAL ± ANGULAR: MACH ± BEND ± TWO PLACE DECIMAL ± THREE PLACE DECIMAL ±	DRAWN				<p>SIZE DWG. NO. REV</p> <p><b>A</b> outside shell</p>
			INTERPRET GEOMETRIC TOLERANCING PER:	CHECKED			<p>SCALE: 1:5 WEIGHT: SHEET 1 OF 1</p>	
			MATERIAL	ENG APPR.				
		NEXT ASSY	USED ON	FINISH	MFG APPR.			
	APPLICATION		DO NOT SCALE DRAWING	Q.A.				
				COMMENTS:				