

[company logo here]

[company name here]

[city, state here]

[company url here]

[name] · [title] · [email address] · (###) ### ####

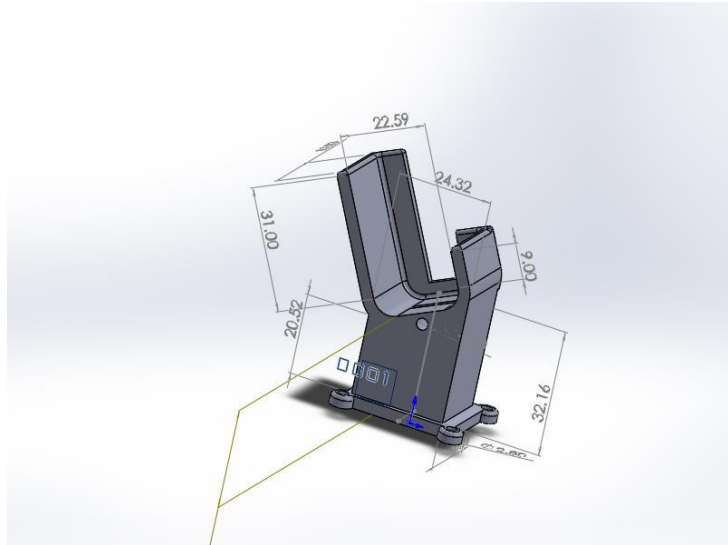

Model Name:	motor support(2)
Material:	Acrylic (Medium-high impact)
Recycled content:	0.00 %
Weight:	20.67 g
Manufacturing process:	Injection Molded
Surface Area:	8242.26 mm ²
Built to last:	1.0 year
Duration of use:	1.0 year



Manufacturing Region

The choice of manufacturing region determines the energy sources and technologies used in the modeled material creation and manufacturing steps of the product's life cycle.

Use Region

The use region is used to determine the energy sources consumed during the product's use phase (if applicable) and the destination for the product at its end-of-life. Together with the manufacturing region, the use region is also used to estimate the environmental impacts associated with transporting the product from its manufacturing location to its use location.

Summary

[Learn more about Life Cycle Assessment](#) 

Sustainability Report

Model Name:	motor support(2)	Material:	Acrylic (Medium-high impact)	Weight:	20.67 g	Manufacturing process:	
		Recycled content:	0.00 %	Surface Area:	8242.26 mm ²		Injection Molded
				Built to last:	1.0 year		
				Duration of use:	1.0 year		

Material Acrylic (Medium-high impact) 0.00 %

Material Unit Cost 2.80 USD/kg

Manufacturing

Region: North America
Process: Injection Molded
Electricity consumption: 1.8E-3 kWh/lbs
Natural gas consumption: 0.00 BTU/lbs
Scrap rate: 2.0 %
Built to last: 1.0 year
Part is painted: No Paint

Use

Region: North America
Duration of use: 1.0 year

Transportation

Truck distance: 2600 km
Train distance: 0.00 km
Ship distance: 0.00 km
Airplane Distance: 0.00 km

End of Life

Recycled: 33 %
Incinerated: 13 %
Landfill: 54 %

Comments

Sustainability Report

Model Name:	motor support(2)	Material:	Acrylic (Medium-high impact)	Weight:	20.67 g	Manufacturing process:	
		Recycled content:	0.00 %	Surface Area:	8242.26 mm ²		Injection Molded
				Built to last:	1.0 year		
				Duration of use:	1.0 year		

Environmental Impact (calculated using CML impact assessment methodology)

Carbon Footprint



0.087 kg CO₂e

Total Energy Consumed



1.4 MJ

Air Acidification



3.0E-4 kg SO₂e

Water Eutrophication



3.5E-5 kg PO₄e

Material Financial Impact 0.06 USD

Comments

[Click here for alternative units such as 'Miles Driven in a Car'](#)



Baseline

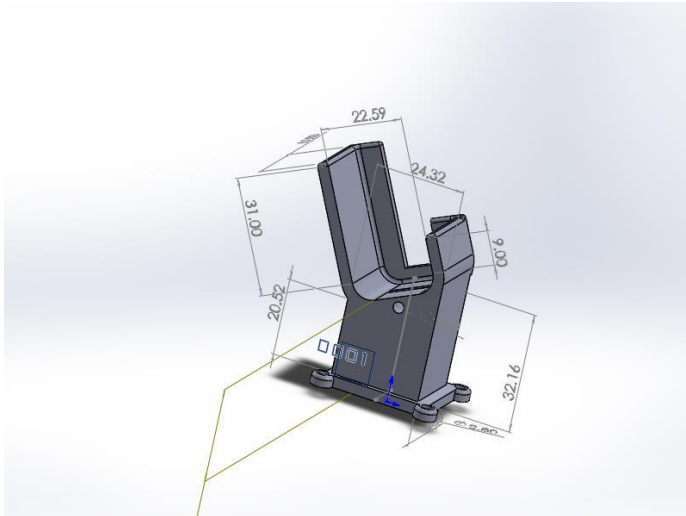

Model Name: motor support(2)

Material: Polyether Polyol

Recycled content: 0.00 %

Weight: 18 g

Manufacturing process: Injection Molded

Surface Area: 8242.26 mm²

Built to last: 1.0 year

Duration of use: 1.0 year



Manufacturing Region

The choice of manufacturing region determines the energy sources and technologies used in the modeled material creation and manufacturing steps of the product's life cycle.

Use Region

The use region is used to determine the energy sources consumed during the product's use phase (if applicable) and the destination for the product at its end-of-life. Together with the manufacturing region, the use region is also used to estimate the environmental impacts associated with transporting the product from its manufacturing location to its use location.

Comments

Sustainability Report

Model Name:	motor support(2)	Material:	Polyether Polyol	Weight:	18 g	Manufacturing process:	
BASELINE		Recycled content:	0.00 %	Surface Area:	8242.26 mm ²		Injection Molded
				Built to last:	1.0 year		
				Duration of use:	1.0 year		

Material Polyether Polyol 0.00 %

Material Unit Cost Not Defined

Manufacturing

Region: North America
Process: Injection Molded
Electricity consumption: 1.8E-3 kWh/lbs
Natural gas consumption: 0.00 BTU/lbs
Scrap rate: 2.0 %
Built to last: 1.0 year
Part is painted: No Paint

Use

Region: North America
Duration of use: 1.0 year

Transportation

Truck distance: 2600 km
Train distance: 0.00 km
Ship distance: 0.00 km
Airplane Distance: 0.00 km

End of Life

Recycled: 33 %
Incinerated: 13 %
Landfill: 54 %

Comments

Sustainability Report

Model Name: motor support(2)

Material: Polyether Polyol

Weight: 18 g

Manufacturing process:

Surface Area: 8242.26 mm²

Injection Molded

BASELINE

Recycled content: 0.00 %

Built to last: 1.0 year

Duration of use: 1.0 year

Environmental Impact Comparison

New Design:

■ Better

■ Worse

Original Design:

■ Baseline

Carbon Footprint - Comparison

Total | Acrylic (Medium-high impact) : 0.087 kg CO₂e
Polyether Polyol : 0.146 kg CO₂e

Total Energy Consumed - Comparison

Total | Acrylic (Medium-high impact) : 1.4 MJ
Polyether Polyol : 1.8 MJ

Air Acidification - Comparison

Total | Acrylic (Medium-high impact) : 3.0E-4 kg SO₂e
Polyether Polyol : 4.0E-4 kg SO₂e

Water Eutrophication - Comparison

Total | Acrylic (Medium-high impact) : 3.5E-5 kg PO₄e
Polyether Polyol : 8.3E-5 kg PO₄e

Material Financial Impact Comparison



Comments

[Click here for alternative units such as 'Miles Driven in a Car'](#)





Glossary

Air Acidification - Sulfur dioxide, nitrous oxides other acidic emissions to air cause an increase in the acidity of rainwater, which in turn acidifies lakes and soil. These acids can make the land and water toxic for plants and aquatic life. Acid rain can also slowly dissolve manmade building materials such as concrete. This impact is typically measured in units of either kg **sulfur dioxide equivalent (SO₂)**, or **moles H⁺ equivalent**.

Carbon Footprint - Carbon-dioxide and other gasses which result from the burning of fossil fuels accumulate in the atmosphere which in turn increases the earth's average temperature. Carbon footprint acts as a proxy for the larger impact factor referred to as Global Warming Potential (GWP). Global warming is blamed for problems like loss of glaciers, extinction of species, and more extreme weather, among others.

Total Energy Consumed - A measure of the non-renewable energy sources associated with the part's lifecycle in units of megajoules (**MJ**). This impact includes not only the electricity or fuels used during the product's lifecycle, but also the upstream energy required to obtain and process these fuels, and the embodied energy of materials which would be released if burned. Total Energy Consumed is expressed as the net calorific value of energy demand from non-renewable resources (e.g. petroleum, natural gas, etc.). Efficiencies in energy conversion (e.g. power, heat, steam, etc.) are taken into account.

Water Eutrophication - When an over abundance of nutrients are added to a water ecosystem, eutrophication occurs. Nitrogen and phosphorous from waste water and agricultural fertilizers causes an overabundance of algae to bloom, which then depletes the water of oxygen and results in the death of both plant and animal life. This impact is typically measured in either kg **phosphate equivalent (PO₄)** or **kg nitrogen (N) equivalent**.

Life Cycle Assessment (LCA) - This is a method to quantitatively assess the environmental impact of a product throughout its entire lifecycle, from the procurement of the raw materials, through the production, distribution, use, disposal and recycling of that product.

Material Financial Impact - This is the financial impact associated with the material only. The mass of the model is multiplied by the financial impact unit (units of currency/units of mass) to calculate the financial impact (in units of currency).

[Learn more about Life Cycle Assessment](#)