

Report

Appendix

2

1

ITEM NO.	PART NUMBER	DESCRIPTION	QTY.
1	Al Extrusions Frame		1
2	Front & Side Wall (Student)	190 x 190	1
3	Front & Side Wall (Student)	270 x 190 w Corner Cuts	2
4	Bottom Panel (Student)		1
5	Back Panel (Student)		1
6	Top Panel (Student)	270 x 190	1
7	Door (Student)	180 x 180 to 190 x 190	1
8	Hinge		2
9	ISO 10642 - M4 x 8 - 8N		8
10	ISO 4762 M4 x 6 - 6N		10
11	Pan Head Self-Tapping Screw #6 3/8"		1

B

B

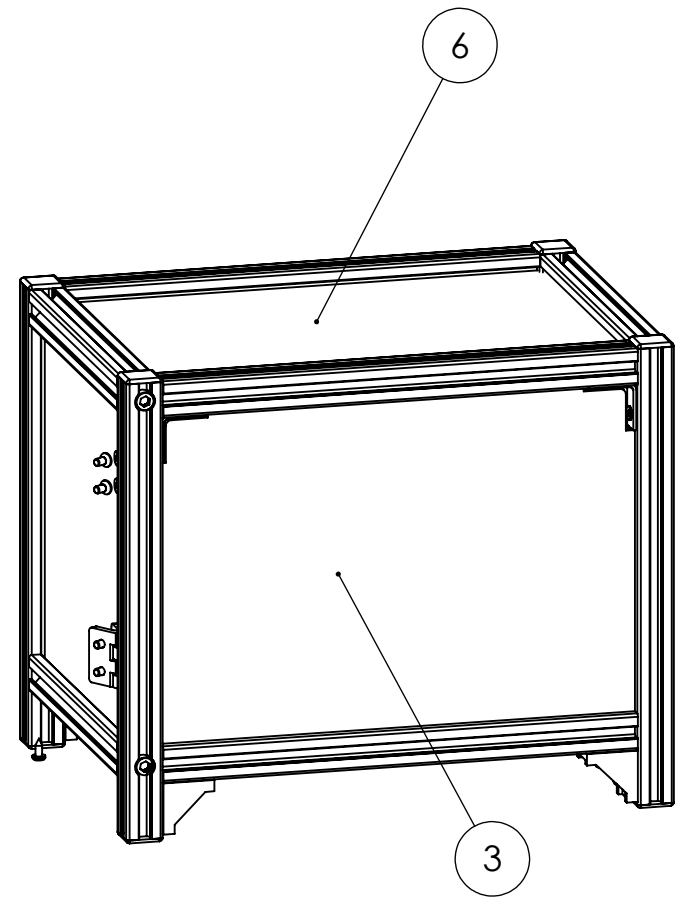
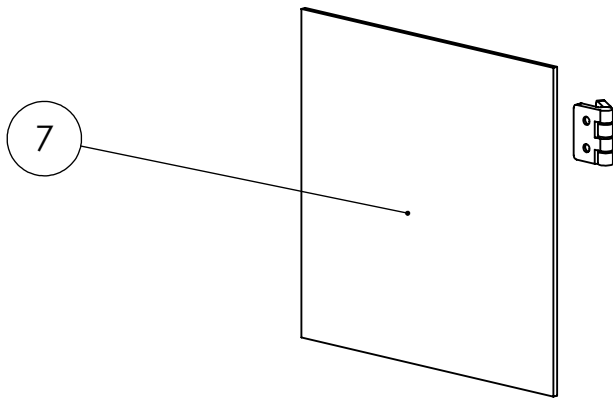

A

A

		UNLESS OTHERWISE SPECIFIED:		NAME	DATE	TITLE:
		DIMENSIONS ARE IN INCHES TOLERANCES: FRACTIONAL ANGULAR: MACH BEND TWO PLACE DECIMAL THREE PLACE DECIMAL	DRAWN			
		INTERPRET GEOMETRIC TOLERANCING PER:	CHECKED			
		MATERIAL	ENG APPR.			
		FINISH	MFG APPR.			SIZE DWG. NO. REV
NEXT ASSY	USED ON		Q.A.			
APPLICATION		DO NOT SCALE DRAWING	COMMENTS:			For L6
			SCALE: 1:4	WEIGHT:	SHEET 1 OF 1	

PROPRIETARY AND CONFIDENTIAL
THE INFORMATION CONTAINED IN THIS DRAWING IS THE SOLE PROPERTY OF <INSERT COMPANY NAME HERE>. ANY REPRODUCTION IN PART OR AS A WHOLE WITHOUT THE WRITTEN PERMISSION OF <INSERT COMPANY NAME HERE> IS PROHIBITED.

2

1