

Project number	Part Number	Explanation	Quantity
1	Hinge		1
2	Side Wall complete	270 x 190 w Corner Cuts	1
3	Front & Side Wall (Student)	270 x 190 w Corner Cuts	1
4	Bottom Panel (Student)		1
5	Back Panel (Student)		1
6	Top Panel draft 2 (Student)	270 x 190	1
7	Hinge		2
8	ISO 10642 - M4 x 8 - 8N		8
9	ISO 4762 M4 x 6 - 6N		10
10	Pan Head Self-Tapping Screw #4 1"	180 x 180 to 190 x 190	1
11	Pan Head Self-Tapping Screw #6 1\2"	180 x 180 to 190 x 190	7
12	Pan Head Self-Tapping Screw #6 3\8"	180 x 180 to 190 x 190	21
13	Pan Head Self-Tapping Screw #6 1\4"	180 x 180 to 190 x 190	1
14	Pan Head Self-Tapping Screw #4 1\4"	180 x 180 to 190 x 190	1
15	Front & Side Wall	190 x 190	1
16	door (Student) (3)	180 x 180 to 190 x 190	1
17	key11.SLDPRT1		1
18	handle.(1)SLDPRT		1
19	lockkey(1)		1

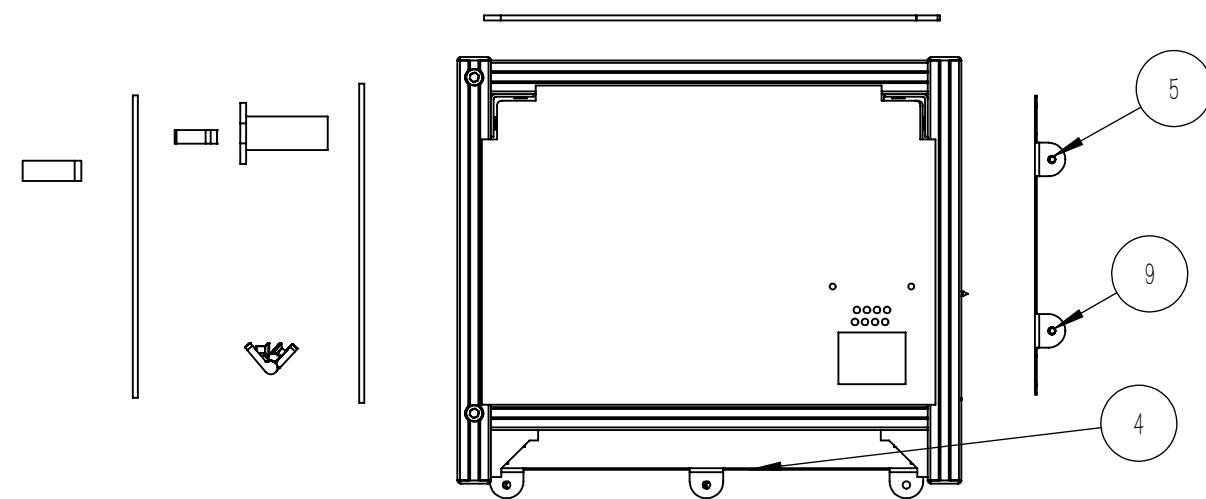
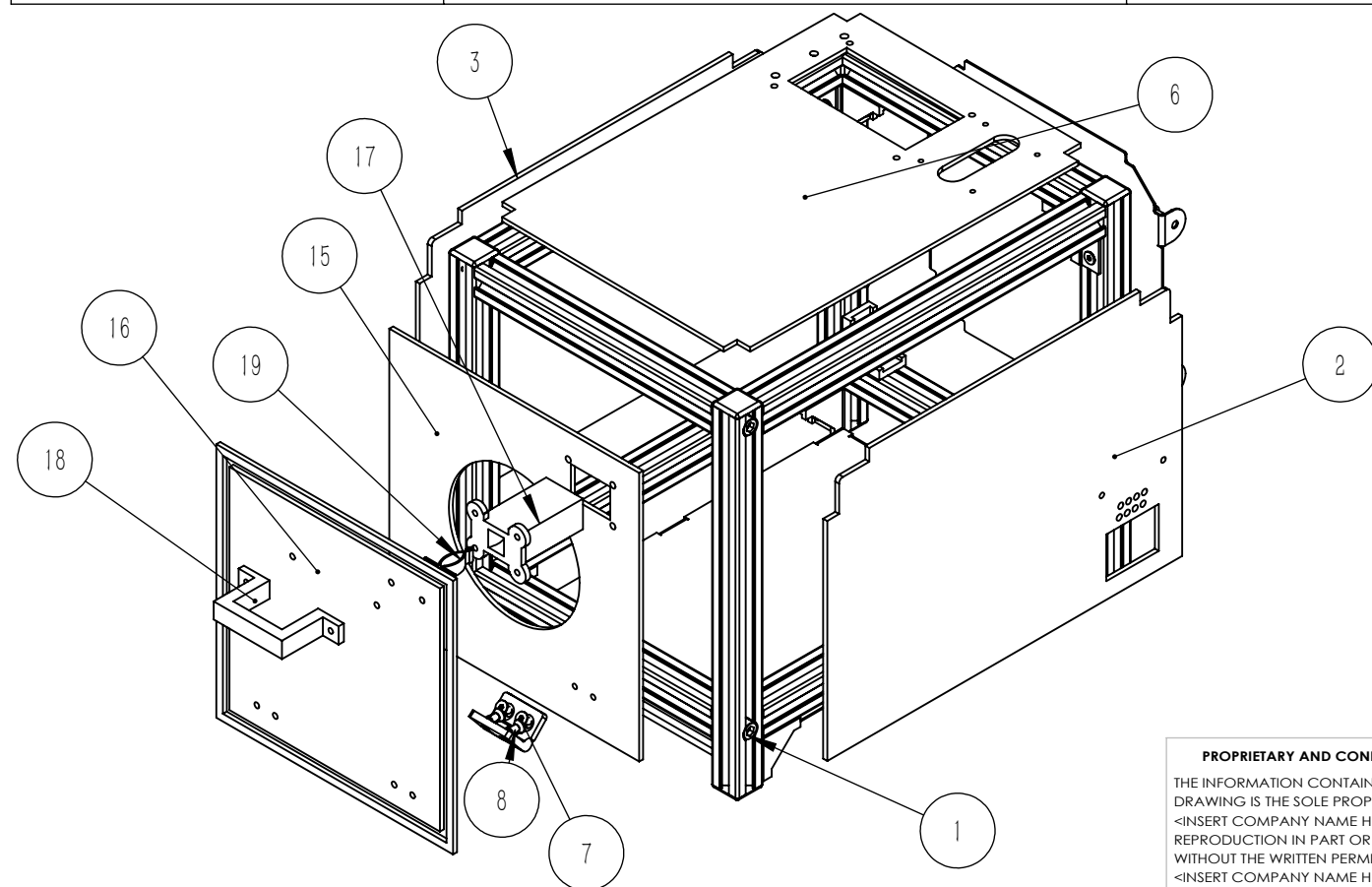

PROPRIETARY AND CONFIDENTIAL
 THE INFORMATION CONTAINED IN THIS DRAWING IS THE SOLE PROPERTY OF <INSERT COMPANY NAME HERE>. ANY REPRODUCTION IN PART OR AS A WHOLE WITHOUT THE WRITTEN PERMISSION OF <INSERT COMPANY NAME HERE> IS PROHIBITED.

		UNLESS OTHERWISE SPECIFIED:	NAME	DATE
		DIMENSIONS ARE IN INCHES	DRAWN	
		TOLERANCES:	CHECKED	
		FRACTIONAL ±	ENG APPR.	
		ANGULAR: MACH ± BEND ±	MFG APPR.	
		TWO PLACE DECIMAL ±	Q.A.	
		THREE PLACE DECIMAL ±	COMMENTS:	
		INTERPRET GEOMETRIC TOLERANCING PER:		
		MATERIAL		
NEXT ASSY	USED ON	FINISH		
APPLICATION		DO NOT SCALE DRAWING		
TITLE: EneRer Dryer (outside)				
SIZE	DWG. NO.	REV		
B		-.01		
SCALE: 1:5		WEIGHT:	SHEET 1 OF 2	